

Shaft coupling design No. 001 - casted materials -

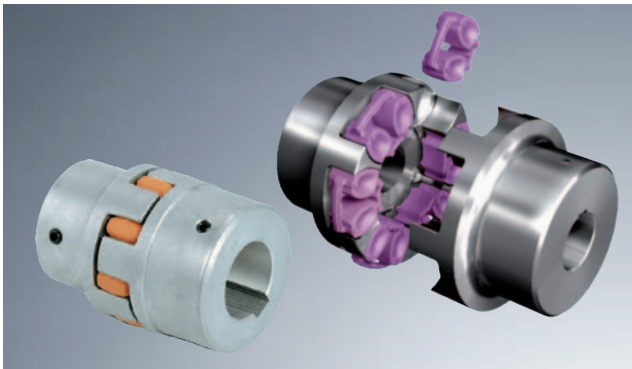

- Torsionally flexible, maintenance-free
- Damping vibrations
- Axial plug-in, fail-safe
- All-over machining (except for aluminium AL-D) – good dynamic properties
- Compact design/low flywheel effect
- Finish bore acc. to ISO tolerance H7, feather keyway acc. to DIN 6885 sheet 1 - JS9
- Stock programme/basic programme see pages 28 and 29
- Approved according to EC standard 94/9/EC (except for aluminium AL-D)
- Mounting instructions at www.ktr.com

Components

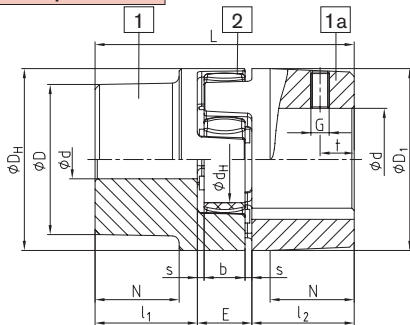

AL-D (thread opposite to the keyway)

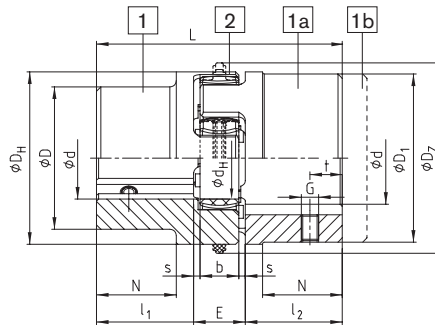

GJL / GJS (thread on the keyway)

Spider
Hardness 92Sh-A,
95/98Sh-A, 64Sh-D
Standard from size
14 - 180

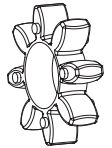

Elements DZ
Hardness 92Sh-A and
95Sh-A size 100 - 180

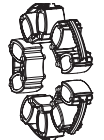

ROTEX® Aluminium diecast (AI-D)

Size	Component	Spider (part 2) ¹⁾ Rated torque [Nm]			Finish bore d (min-max)	Dimensions [mm]													
		92 Sh-A	98 Sh-A	64 Sh-D		General											Thread for setscrew		
						L	l ₁ ; l ₂	E	b	s	D _H	D _Z	d _H	D _i ; D ₁	N	G	t	T _A [Nm]	
14 ²⁾	1a	7,5	12,5	—	6-16	35	11	13	10	1,5	30	—	10	30	—	M4	5	1,5	
19	1	10	17	—	6-19	66	25	16	12	2	41	—	18	32	20	M5	10	2	
	41																		
24	1	35	60	—	9-24	78	30	18	14	2	56	—	27	40	24	M5	10	2	
	56																		
28	1	95	160	—	10-28	90	35	20	15	2,5	66	—	30	48	28	M8	15	10	
	66																		

ROTEX® Cast iron (GJL)

38	1	190	325	405	12-40	114	45	24	18	3	80	—	38	66	37	M8	15	10
	38-48				78													
	12-48				62													
42	1	265	450	560	14-45	126	50	26	20	3	95	—	46	75	40	M8	20	10
	42-55				94													
	14-55				65													
48	1	310	525	655	15-52	140	56	28	21	3,5	105	—	51	85	45	M8	20	10
	48-62				104													
	15-62				69													
55	1	410	685	825	20-60	160	65	30	22	4	120	—	60	98	52	M10	20	17
	55-74				118													
65	1	625	940	1175	22-70	185	75	35	26	4,5	135	—	68	115	61	M10	20	17
75	1	1280	1920	2400	30-80	210	85	40	30	5	160	—	80	135	69	M10	25	17
90	1	2400	3600	4500	40-97	245	100	45	34	5,5	200	218	100	160	81	M12	30	40

ROTEX® Nodular iron (GJS)

100	1	3300	4950	6185	50-115	270	110	50	38	6	225	246	113	180	89	M12	30	40
110	1	4800	7200	9000	60-125	295	120	55	42	6,5	255	276	127	200	96	M16	35	80
125	1	6650	10000	12500	60-145	340	140	60	46	7	290	315	147	230	112	M16	40	80
140	1	8550	12800	16000	60-160	375	155	65	50	7,5	320	345	165	255	124	M20	45	140
160	1	12800	19200	24000	80-185	425	175	75	57	9	370	400	190	290	140	M20	50	140
180	1	18650	28000	35000	85-200	475	195	85	64	10,5	420	450	220	325	156	M20	50	140

■ = If no material is mentioned in the order, it is stipulated in the calculation/order.

¹⁾ Maximum torque of the coupling TK_{max}. = rated torque of the coupling TK_{Nenn}. x 2. see page 20/21 for selection.

²⁾ Material Al-H.

Ordering example:

ROTEX® 38	GJL	92 Sh-A	1a	Ø 45	1	Ø 25
Coupling size	Material	Spider hardness	Component	Finish bore	Component	Finish bore