

Selection and sizing according to DIN 808 with plain/needle bearing

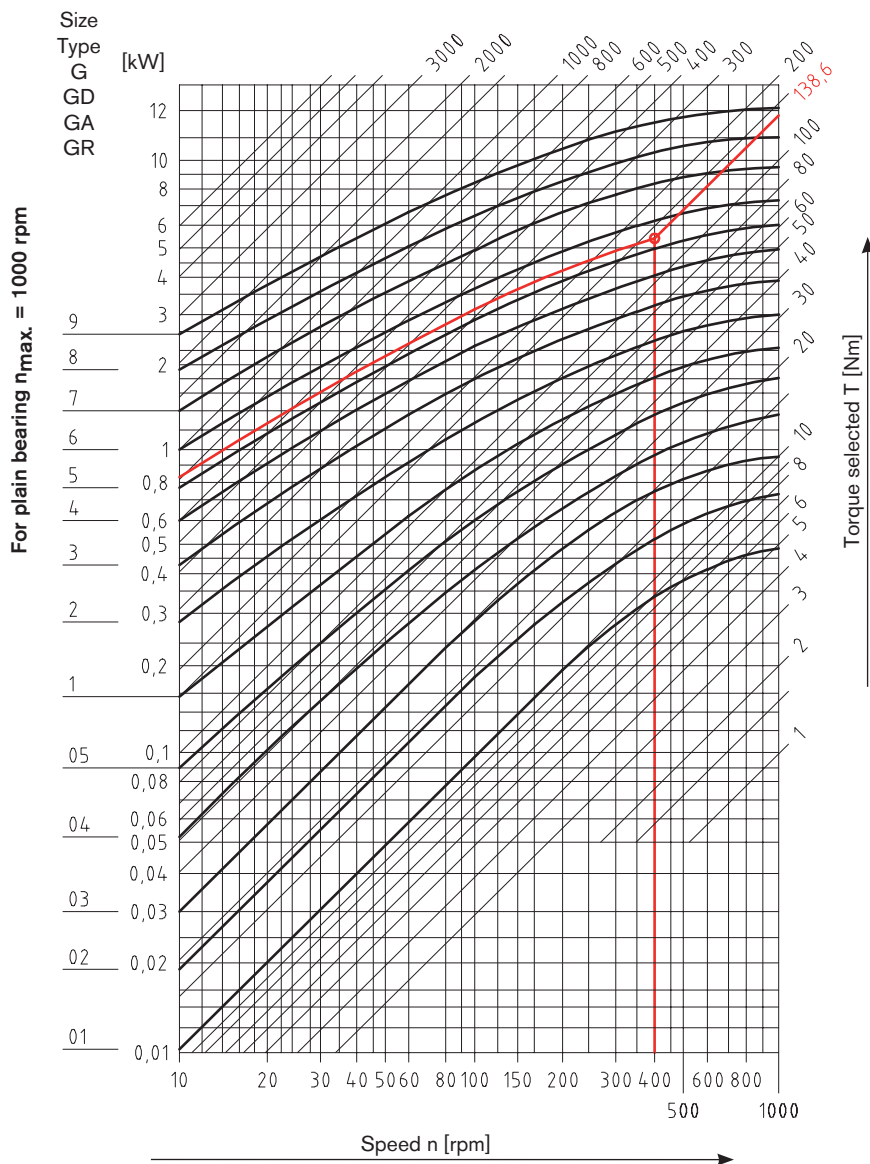

Selection of type G, GD, GA, GR (max. 1000 rpm) ¹⁾

The selection of precision joints with plain bearing is based on the driving torque considering a correction factor which depends on the diffraction angle α and the operating speed.

For extendable joints the overall length and the speed need to be additionally considered for sizing (please consult with KTR).

$$\text{Driving torque } M_t \text{ [Nm]} = 9550 \cdot \frac{\text{Power [kW]}}{\text{Speed [rpm]}}$$

$$\text{Torque selected } T \text{ [Nm]} = \text{driving torque} \cdot \text{correction factor}$$

Additional review:

$$\text{Diffraction angle } [\alpha] \cdot \text{speed [rpm]} \leq 40,000$$

Diffraction angle $[\alpha]$	5°	10°	15°	20°	25°	30°	35°	40°	45°
Correction factor	0.8	1.00	1.25	1.5	1.8	2.2	2.6	3.3	4.0

Details given:

Driving torque M_t 63 Nm
 Diffraction angle 30° → Correction factor for diffraction angle 2.2
 Operating speed 400 rpm

$$\text{Torque selected } T \text{ [Nm]} = 63 \text{ Nm} \cdot 2.2 \rightarrow 138.6 \text{ Nm}$$

Selection based on table: [joint size 6](#)

KTR Precision joints type G and GD

According to DIN 808 with plain bearing

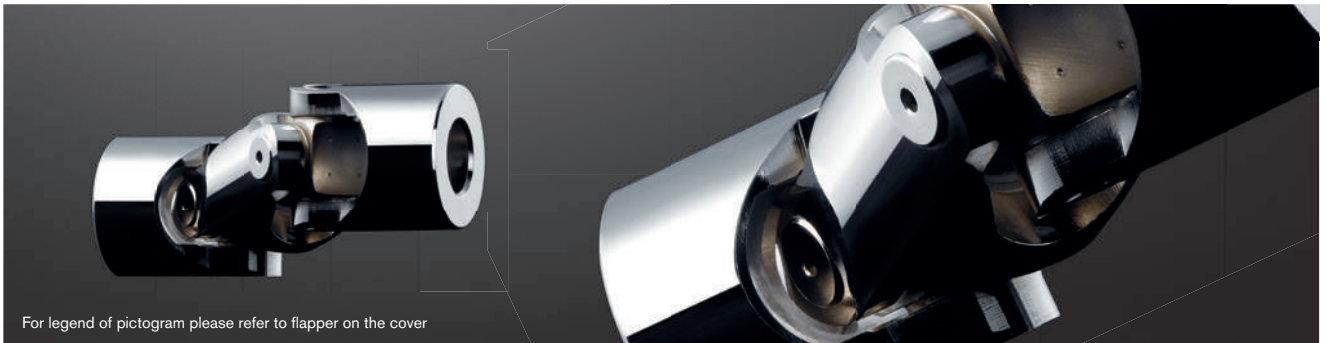

For legend of pictogram please refer to flapper on the cover



Precision single joint G

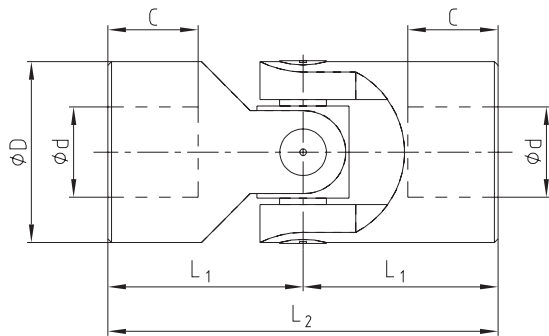

Precision double joint GD

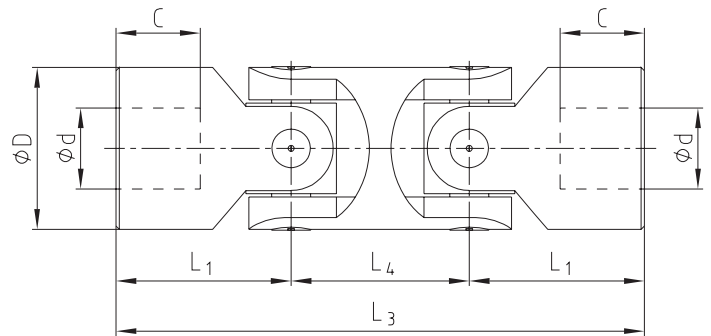

Finish bores:

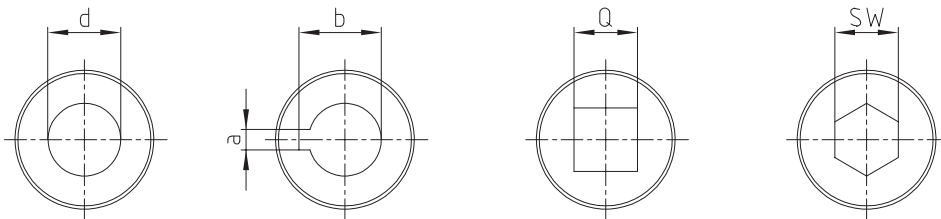

Type G and GD																
Types and size															Weight [kg]	
Size G	DIN designation G	Size GD	DIN designation GD	d (H7)	D	L ₂	L ₁	C	L ₄	L ₃	a (JS9)	b	Q (H10)	SW (H10)	G	GD
01 G	E6 x 16-G	01 GD	D6 x 16-G	6	16	34	17	8	22	56	2	7.0	6	6	0.05	0.08
02 G	E8 x 16-G	02 GD	D8 x 16-G	8	16	40	20	11	22	62	2	9.0	8	8	0.05	0.08
03 G	E10 x 22-G	03 GD	D10 x 22-G	10	22	48	24	12	26	74	3	11.4	10	10	0.10	0.15
04 G	E12 x 25-G	04 GD	D12 x 25-G	12	25	56	28	13	30	86	4	13.8	12	12	0.16	0.25
05 G	E14 x 28-G	05 GD	D14 x 28-G	14	28	60	30	14	36	96	5	16.3	14	14	0.20	0.40
1 G	E16 x 32-G	1 GD	D16 x 32-G	16	32	68	34	16	37	105	5	18.3	16	16	0.30	0.45
2 G	E18 x 36-G	2 GD	D18 x 36-G	18	36	74	37	17	40	114	6	20.8	18	18	0.45	0.70
3 G	E20 x 42-G	3 GD	D20 x 42-G	20	42	82	41	18	47	129	6	22.8	20	20	0.60	1.00
4 G	E22 x 45-G	4 GD	D22 x 45-G	22	45	95	47.5	22	50	145	6	24.8	22	22	0.95	1.55
5 G	E25 x 50-G	5 GD	D25 x 50-G	25	50	108	54	26	55	163	8	28.3	25	25	1.20	2.00
6 G	E30 x 58-G	6 GD	D30 x 58-G	30	58	122	61	29	68	190	8	33.3	30	30	1.85	2.90
6 G1	E32 x 58-G	6 GD1	D32 x 58-G	32	58	130	65	33	68	198	10	35.3	30	30	2.00	3.00
7 G	E35 x 70-G	7 GD	D35 x 70-G	35	70	140	70	33	72	212	10	38.3	-	-	3.15	4.75
8 G	E40 x 80-G	8 GD	D40 x 80-G	40	80	160	80	38	85	245	12	43.3	-	-	4.60	7.20
9 G	E50 x 95-G	9 GD	D50 x 95-G	50	95	190	95	46	100	290	14	53.8	-	-	7.60	12.0

Ordering example:	04 G	Ø12	Ø12 keyway to DIN
	Size and type of joint	Finish bore (H7)	Finish bore (H7), feather keyway acc. to DIN 6885 sheet 1 (JS9)